

Base

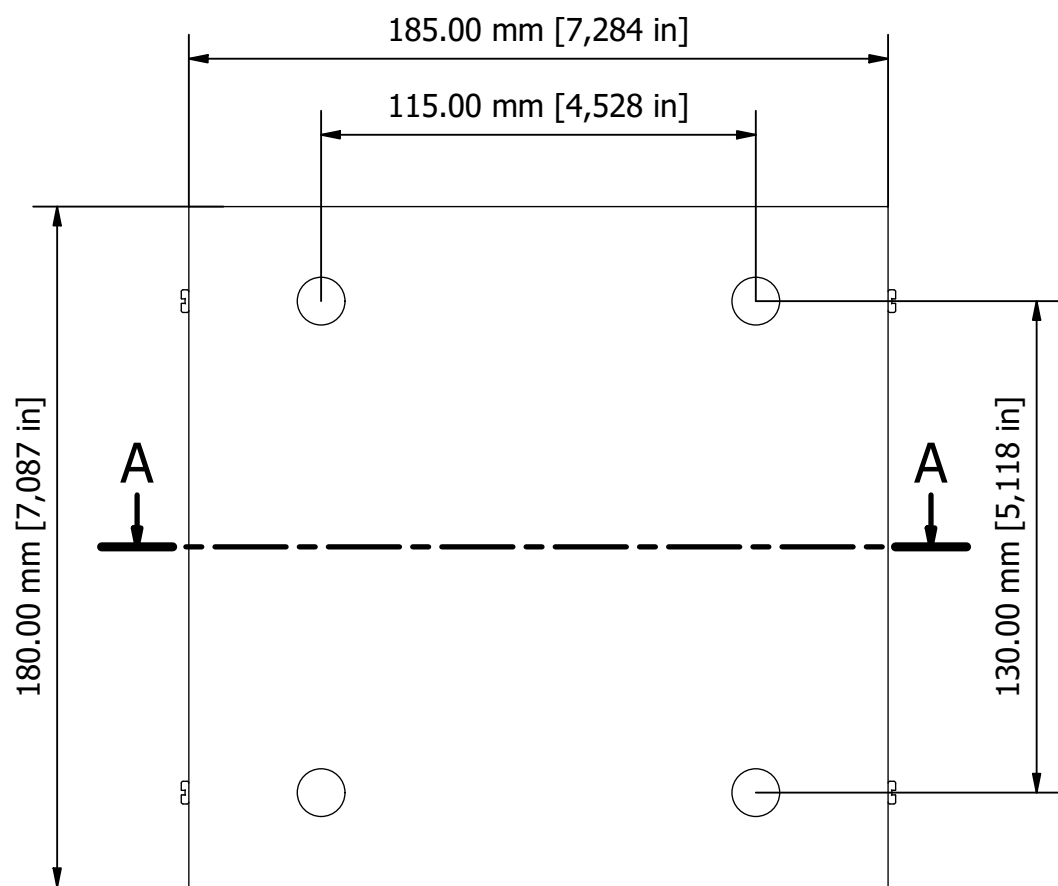

PARTS LIST			
ITEM	QTY	PART NUMBER	DESCRIPTION
1	2	M5400002	Extrusion
4	1	M5403016	Unibase Assembly Kit
5	1	M5409002	Top Cover
6	1	M5409114	Base Panel
7	2	M5402001	Front/Rear Panel

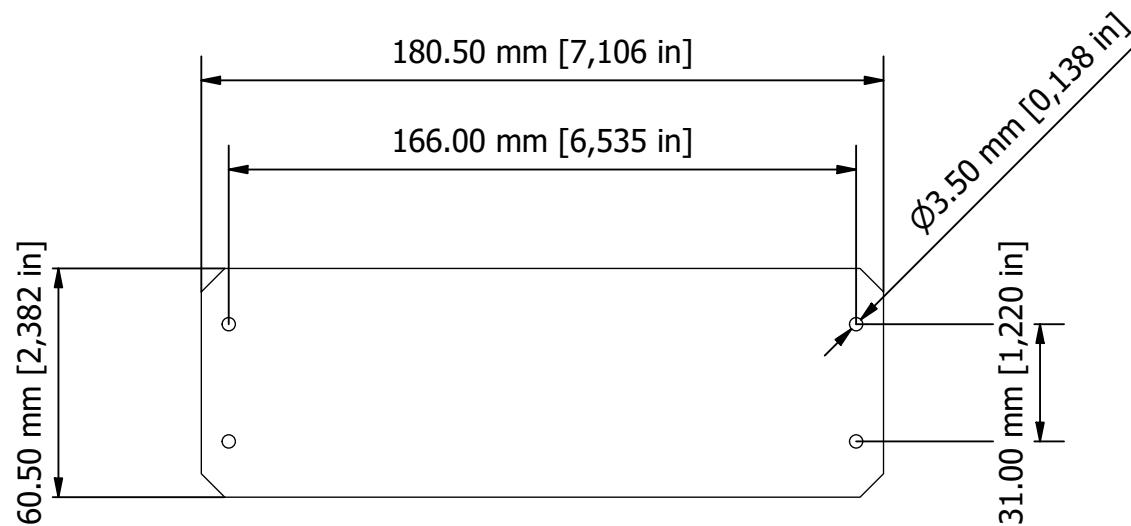

Anodised Front Panel
2 off - 2mm Thick.

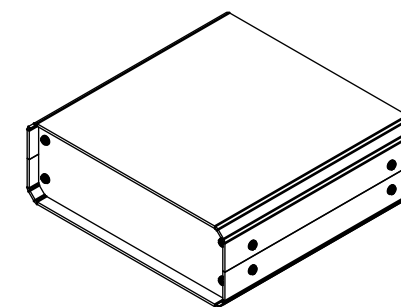

Front

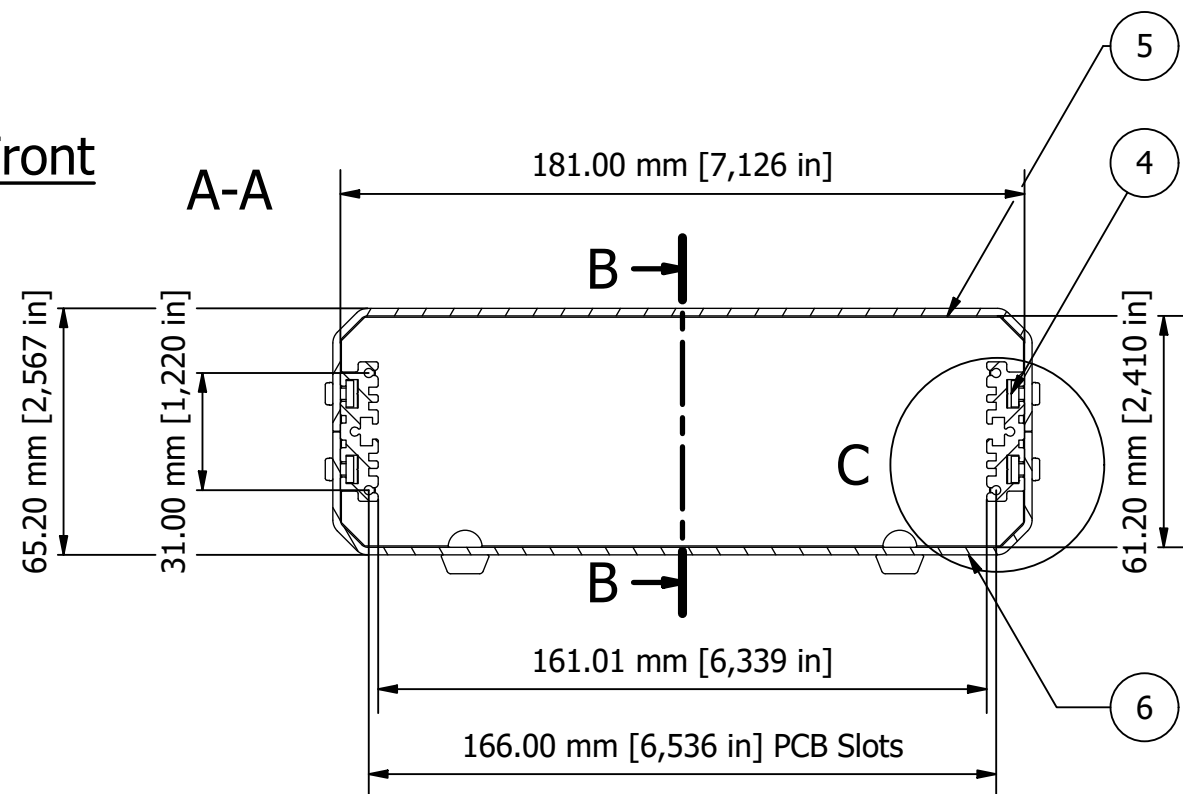

Side

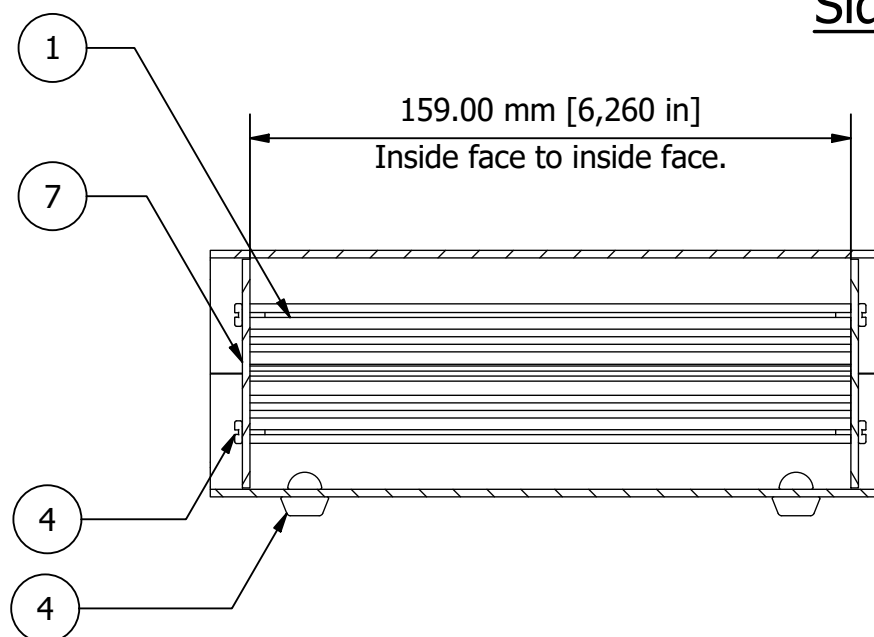

Detail C

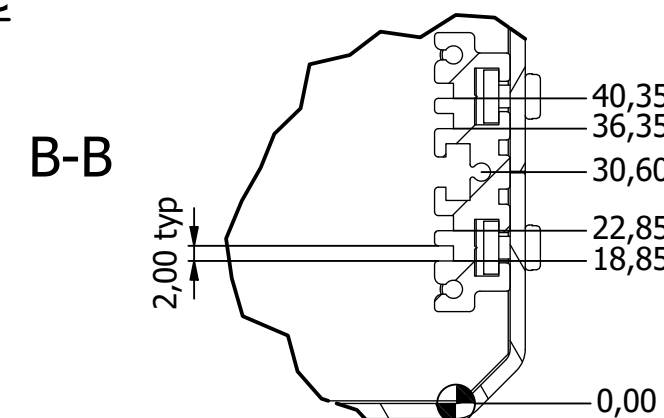

FIRST ANGLE PROJECTION

Designed by L Clark	Description UNICASE 1 BLACK	Date 26/05/2015	Scale 1:2
METCASE ENCLOSURES 15 Brunel Way, Segensworth East, Fareham, Hampshire, UK. PO15 5TX Tel: +44 (0)1489 583858 Email: metcase@okw.co.uk		METcase™ www.metcase.com Part Number M5501119	
		Issue 1	Sheet 1 / 1

© OKW Enclosures Ltd (Date as shown). This drawing contains proprietary information of OKW Enclosures Ltd and is tendered subject to the following conditions. The information be retained in confidence, not be reproduced or copied, and not be used or incorporated in any product, unless permission is obtained in writing from OKW Enclosures Ltd.