

PARTS LIST			
ITEM	QTY	PART NUMBER	DESCRIPTION
3	1	M5403016	Unicase Assembly Kit
4	2	M5400003	Extrusion
5	2	M5402022	Front/Rear Panel
6	1	M5401052	Top Panel
7	1	M5401152	Base Panel

Base

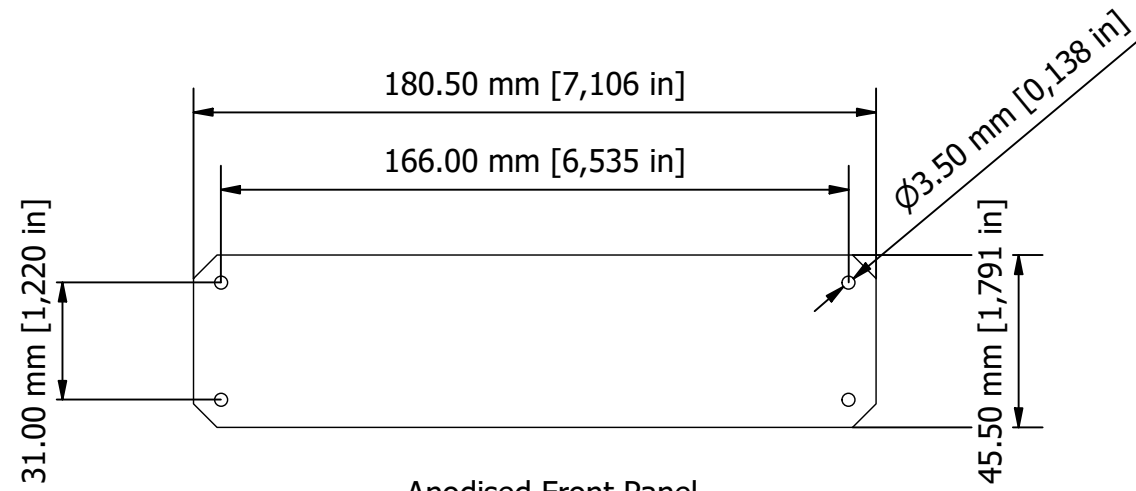

Anodised Front Panel
2 off - 2mm Thick.

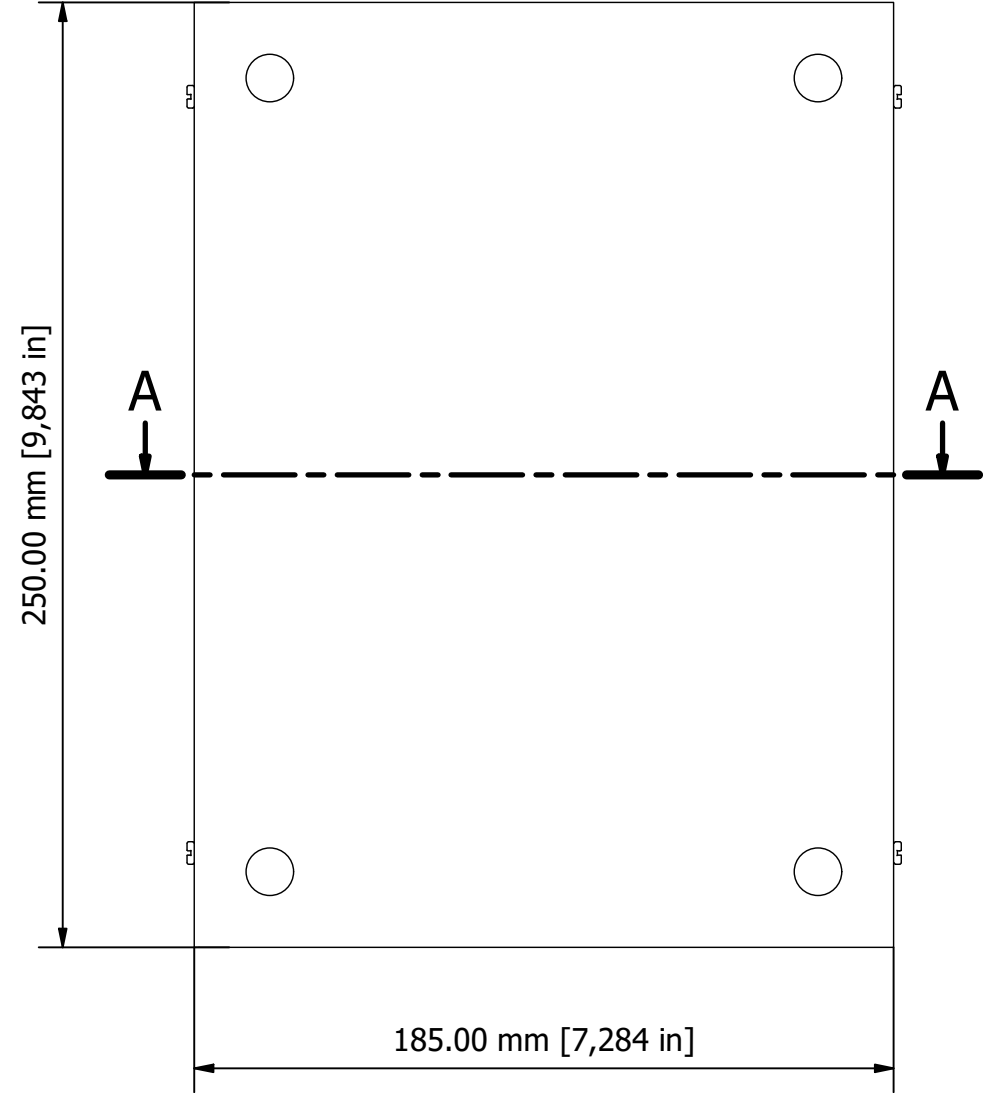
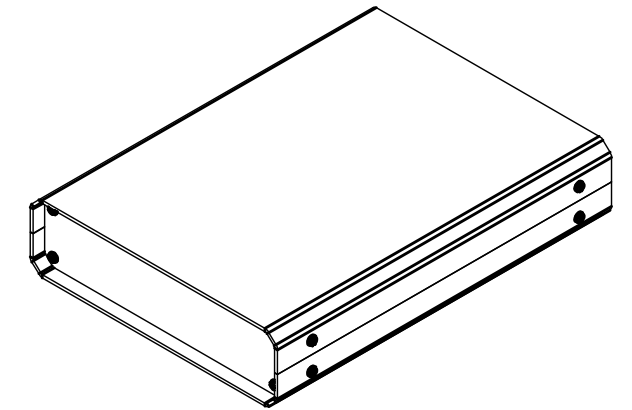

Front

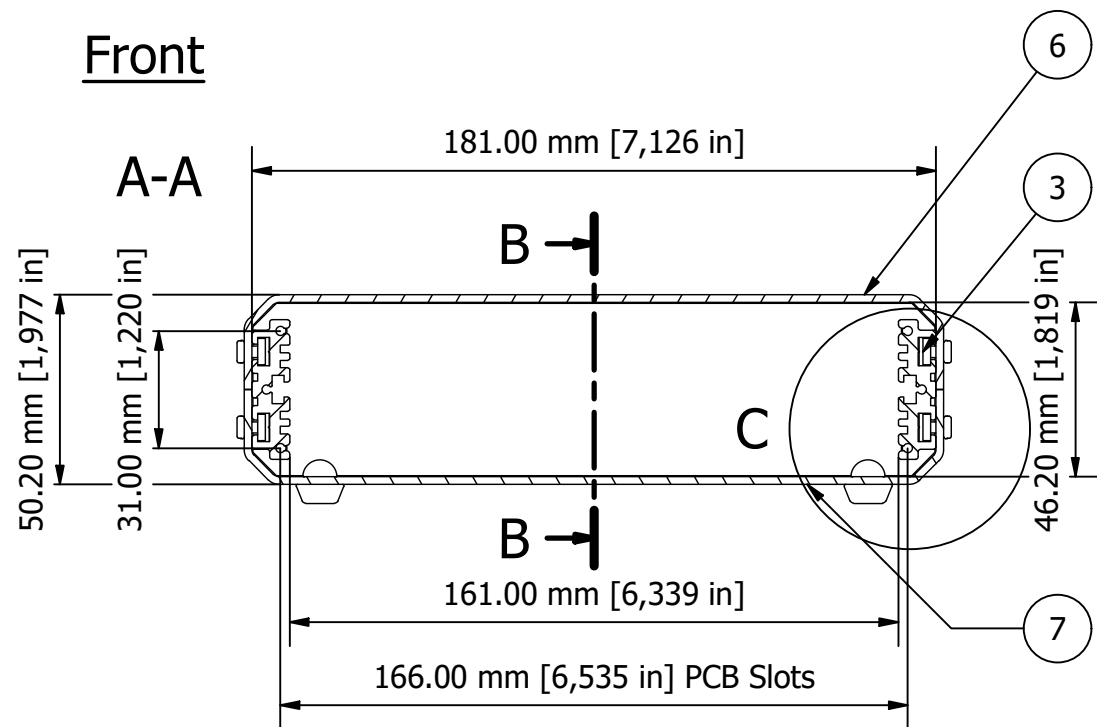

Side

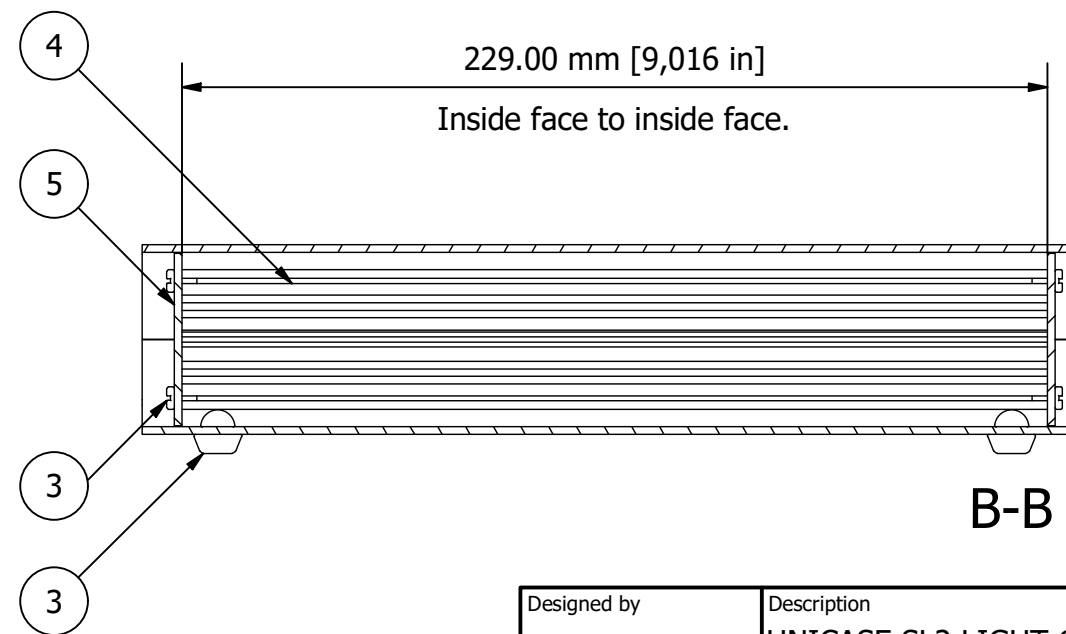

Detail C

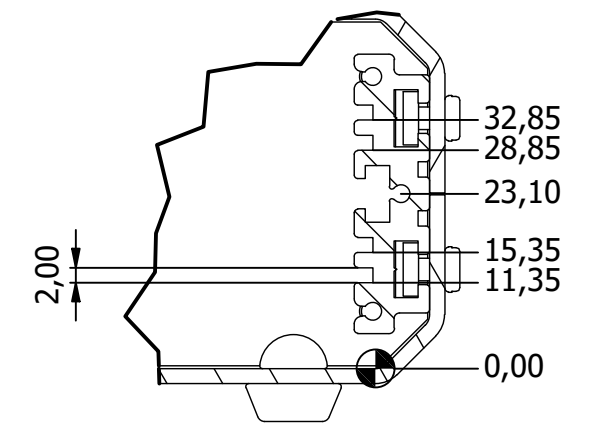

FIRST ANGLE PROJECTION

Designed by L Clark	Description UNICASE SL2 LIGHT GREY	Date 02/07/2013	Scale 1:2
METCASE ENCLOSURES 15 Brunel Way, Segensworth East, Fareham, Hampshire, UK. PO15 5TX Tel: +44 (0)1489 583858 Email: metcase@okw.co.uk		METcase™ www.metcase.com Part Number M5512110	
		Issue 1	Sheet 1 / 1

© OKW Enclosures Ltd (Date as shown). This drawing contains proprietary information of OKW Enclosures Ltd and is tendered subject to the following conditions. The information be retained in confidence, not be reproduced or copied, and not be used or incorporated in any product, unless permission is obtained in writing from OKW Enclosures Ltd.